

Profile Dimensions

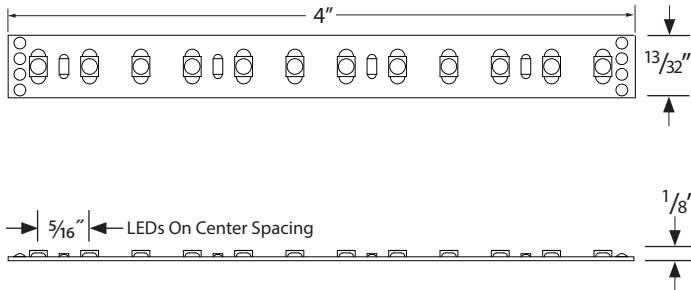

Please verify the contents of the packages!

Please read instructions entirely before starting installation
Be sure power is turned off before installing or modifying the system

Call Tivoli, LLC tech support with questions

Caution: Tivotape™ LED is designed to work with listed Class 2, 24V DC transformers only. Use of any other power source will cause damage, shorten the life of the fixture and will void the warranty.

Consult any and all applicable local and national codes for installation.

Do not conceal or extend exposed conductors through a building wall as per local electrical code.

Warning: With any luminaire for any application, basic safety precautions should always be followed to reduce the risk of fire, electric shock and personal injuries. This lighting system should be installed by a certified professional.



Installation Instructions

CAUTION - Risk of Damage. Handle carefully.

1. **Do not** twist, bend, fold or crease Tivotape™.
2. **Do not** attempt to remove Tivotape™ once it has been installed. Attempting to pull Tivotape™ away from mounting surface after it has been adhered will cause damage to the product.
4. **Do not** use chemical solvents on Tivotape™ during routine maintenance.

Failure to comply will damage the product and void the warranty.

Option 1: Direct to Surface

Note: Use in clean, smooth, surface applications. Attaching to textured surfaces without the use of a mounting channel is not recommended.

Step 1: Unwind Tivotape™ from roll and cut to length according to project layout.

Step 2: Trim off excess length at cutoff zones only.

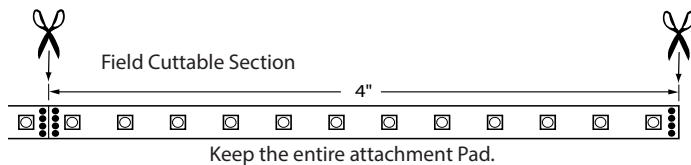

Step 3: Make sure surface where Tivotape™ is to be installed is smooth, clean, free of dirt, oil and debris.

Note: For backing tape to remain permanently attached, mounting surface must be clean and free of oil and debris.

Caution: Do not attempt to remove Tivotape™ once it has been adhered to surface. Stick down once to avoid damage to the product. If there is a misapplication, remove the Tivotape™, clean off all adhesive from the mounting surface and start over with a new strip of Tivotape™ on a clean surface.

Make Connections Using Tivotape™ Connectors

Use the included Connectors to connect Tivotape™ to power source and to interconnect segments of Tivotape™

Step 4: Locate the Wire Lead and pull open the locking face, as shown.

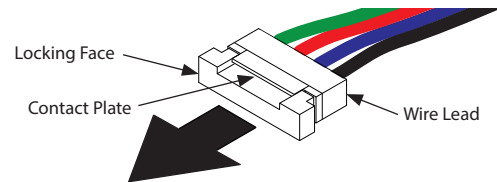

Step 5: IMPORTANT! Use a small utility knife to scrape the eXoShield™ coating from each of the Pads and peel away the 3M VHB backing tape just from the end of the Tivotape™.

WARNING! Risk of product failure.

The eXoShield™ coating must be scraped away from the contact pads in order to create a solid electrical connection.

Step 6: Connect a wire Lead to the Lead End of the run.

Caution: Orient the Connector so the small white Contact Plate at the opening of the Connector is facing up.

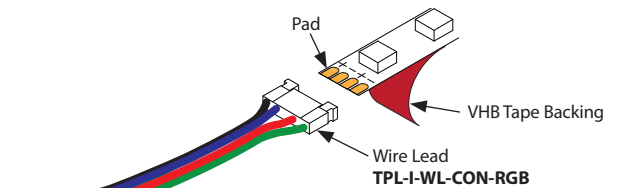

Step 6: Press the Locking Face all the way in to lock the Connector onto the Tivotape™.

Step 7: Continue to peel away the backing tape as the Tivotape™ is applied to a clean, smooth, surface area.

Step 8: Press firmly with hand along the entire length of Tivotape™ to ensure a strong bond to the mounting surface.

Step 9: Connect additional segments of Tivotape™ using supplied connectors. It is recommended that all connectors are attached to Tivotape™ before applying it to surface as described in Steps 5 through 8.

Step 10: Make electrical connections.

Installation Instructions (Continued)

Option 2: Mounting Channel

Mounting channels are recommended for most applications to create a smooth, flat adhesion surface and also to create different visual effects. Some styles of Channel may require a different Installation method than described below. Consult factory for details.

Step 1: Measure and cut mounting channel from supplied lengths to fit full length of mounting surface and drill countersunk mounting holes every 24" along channel.

Step 2: Attach mounting channel using No. 6 Flat Head screws (supplied by others) appropriate for mounting surface, ie: wood screws for wood.

Step 3: Make sure channel surface where Tivotape™ is to be installed is smooth, clean, free of all dirt, oil and debris. **Note:** Cleaning the channel mounting surface with alcohol is recommended.

Make Connections Using Tivotape™ Connectors

Use the included Connectors to connect Tivotape™ to power source and to interconnect segments of Tivotape™

Step 4: Locate the Wire Lead and pull open the locking face, as shown.

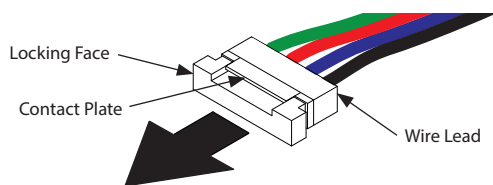

Note: Ten each of five Connector options are included with your Tivotape™ order.

Warning: Do not exceed the maximum linear run length per circuit. Max run lengths vary based on power Supply. See page 4 for details.

Step 5: IMPORTANT! Use a small utility knife to scrape the eXoShield™ coating from each of the Pads and peel away the 3M VHB backing tape just from the end of the Tivotape™.

WARNING! Risk of product failure.

The eXoShield™ coating must be scraped away from the contact pads in order to create a solid electrical connection.

Step 6: Connect a Wire Lead to the Lead End of the run.

Caution: Orient the Connector so the small white Contact Plate at the opening of the Connector is facing up.

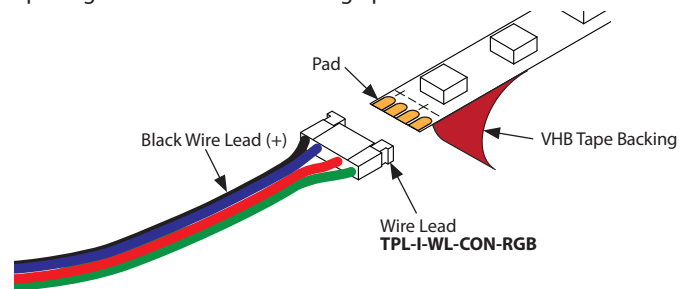

Step 7: Press the Locking Face all the way in to lock the Connector onto the Tivotape™.

Step 8: Continue to peel away the backing tape as the Tivotape™ is applied to a clean, smooth channel surface.

Warning: Do not exceed the maximum linear run length per circuit. Max run lengths vary based on power Supply. See page 4 for details.

Step 9: Install Lens and End Caps as required for application.

Step 10: Connect additional segments of Tivotape™ using supplied connectors. It is recommended that all connectors are attached to Tivotape™ before applying it to surface as described in Steps 5 through 8.

Step 11: Make electrical connections.

Note: Use the included connector options to run Tivotape™ around corners and to join multiple segments of Tivotape™ together.

Power Leads and Jumper Connectors

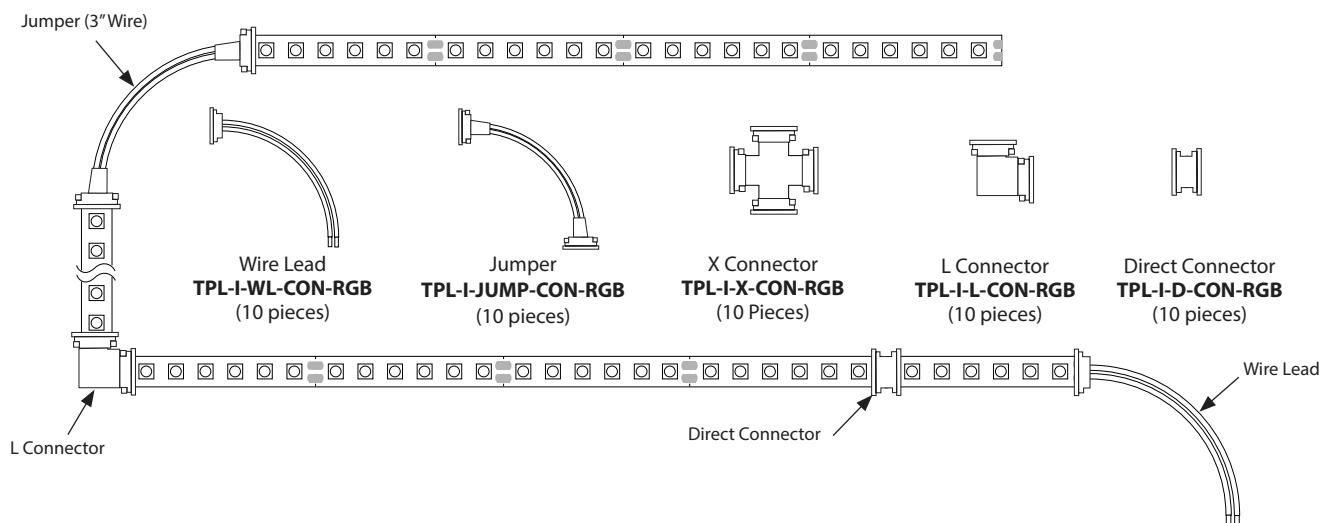

Compatible Channels*

*Lenses and End Caps available separately. Refer to Tivotape™ specification sheets for details.

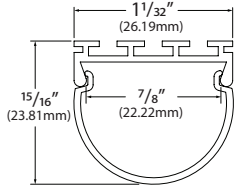

DOME-CHAN-SLV-6.5*
Anodized Aluminum Extrusion, available in 6.5' lengths.

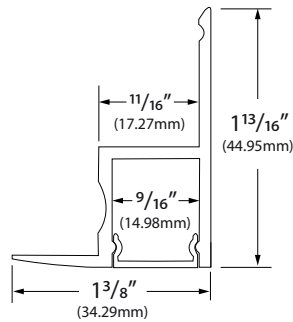

EDGE-CHAN-WHT-6.5 (WHITE)*
EDGE-CHAN-SLV-6.5 (SLIVER)*
Aluminum Ceiling Edge Lit Channel with flush frosted lens (included), Finish options in white and silver, available in 6.5' lengths.

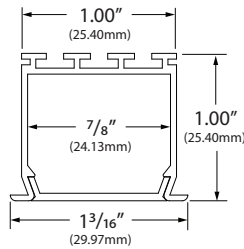

LOKM-CHAN-6.5*
Anodized Channel with flush lens, clips into **TKUS** channel (optional) available in 6.5' lengths

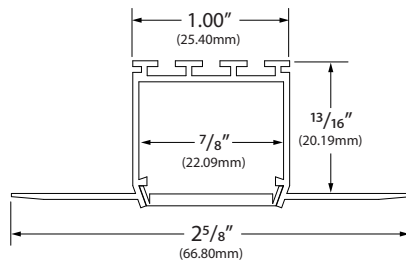

KOZL-CHAN-6.5*
Aluminum channel with flush lens, available in 6.5' length

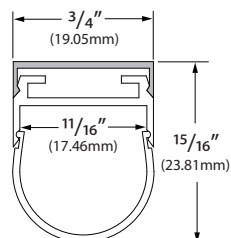

TPL-AL-CHAN-1A-8*
AL Series Aluminum Channel with Mounting Carrier Base. Available in 8 ft standard lengths.

Tivotape™ Variable Indoor Wiring Diagram for 5 Channel DMX Digital Decoder

Electrical Connections for Variable Indoor Tivotape™

Step 1: Turn power off before beginning electrical installation.
Note: Contacting hot wires against the Tivotape™ leads may damage the product and void the warranty.

Step 2: Connect Tivotape™ lead wires to RGBW-Sub-Controller, or if using our ADUL-DIN series transformers, connect to pre-wired terminal blocks which are found inside the power supply box. Refer to diagram below. Make sure each lead wire is connected to the correct terminal, as follows:

TIVOTAPE™ PAD DESIGNATION	FULL ROLL CONNECTOR WIRE COLOR	SUB-CONTROLLER TERMINAL OR ADUL-DIN CONNECTOR WIRE COLOR
+	Green (+)	Black (+)
-	Red (-)	Red (-)
+	Blue (+)	Black (+)
-	Black (-)	Green (-)

Step 3: Connect to a listed Class 2, 24V DC transformer only. See list of approved transformers.

Step 4: Optionally, Variable Tivotape™ may be dimmed using an MLV or ELV dimmer that is suitable for the power supply. Please contact our technical support staff for more information.

Product Specification Guide

LIGHT SOURCE	MAX CONTINUOUS RUN LENGTH*
All color temperatures	32ft

*Max continuous run based on ADUL 96W/4.0A Power Supply max load. (Refer to Tivotape™ Specification Sheets for max run using other recommended power supplies.)

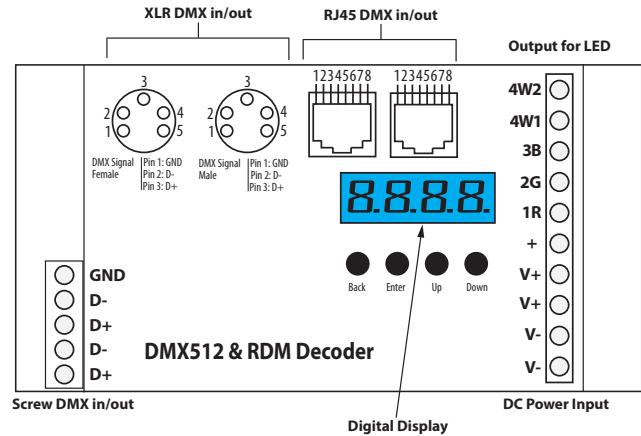

Basic Sub-Controller

DESCRIPTION	CAT NO	MODES	OUTPUT POWER	PRIMARY VOLTAGE	DIMENSION
DMX Subcontroller	TPL-RGBW-180-24	Subcontroller only	5X(96-192)W	24V DC	2.85" W X 6.45" L X 1.5" H

- DMX512 RDM decoder, RDM function can provide the interface between DMX master and decoder. for example, DMX decoder's address may be set from DMX master console.
- Multiple kinds of DMX in/out ports: RJ 45, XLR, normal screws.
- Total 5 PWM output channels, common anode. DMX channel quantity from 1CH~5CH programmable
- PWM output resolution ratio 8bit, 16bit settable.
- Output PWM frequency from 500HZ ~ 9K HZ settable.
- Output dimming curve gamma value from 0.1 ~ 9.9 settable.
- Programmable Decoding mode.

Safety and Warnings:

- Do not install with power applied to device.
- Do not expose to moisture.

Note: The Installation Instructions for your power supply includes DMX programming instructions.

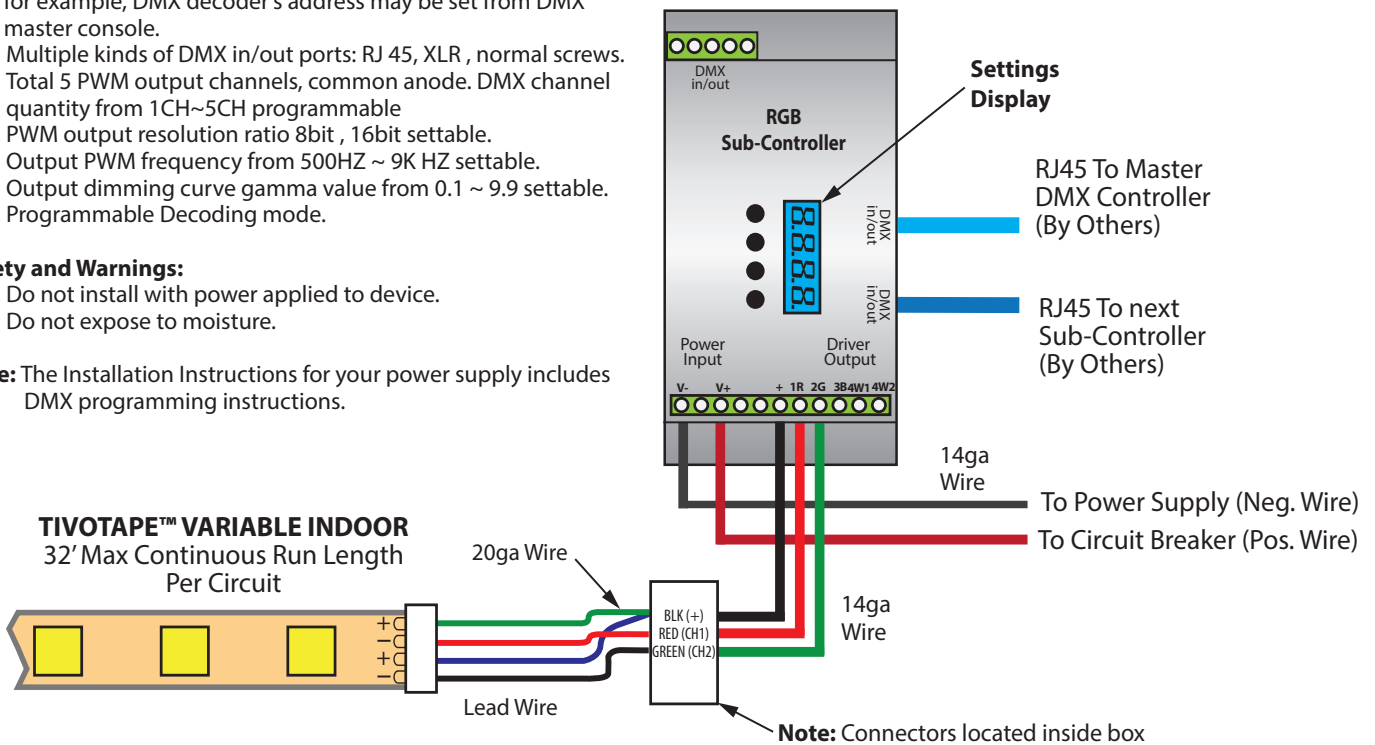

Power Supply with Sub-Controller Sample Wiring Diagram

There are many possible options for controlling Variable Tivotape™. See the specification Sheet for more information. The following wiring diagram is for reference only. Please refer to the Installation Instruction for the Power Supply you choose for detailed wiring instructions.

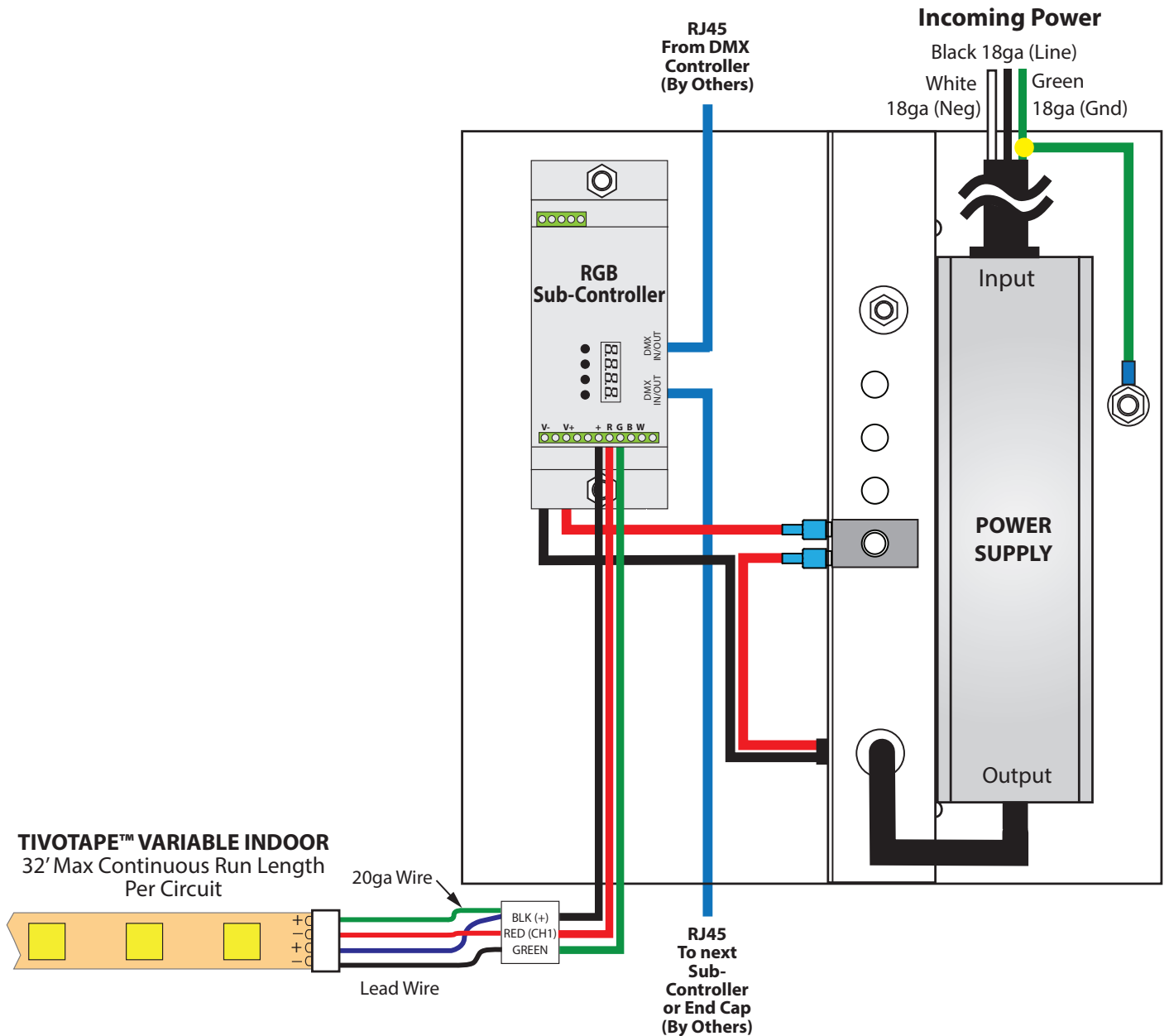

Tivotape™ Variable Indoor Wiring Diagram for 3 Channel Decoder

Install Transformer Enclosure

Step 1: Locate Transformer enclosure in a suitable indoor or outdoor location. Power supply enclosure is water-tight and may be installed in outdoor wet environments.

Step 2: Connect Transformer input to 120-277V AC line voltage.

Step 3: Connect each luminaire linear run to one on the 3 circuit connectors. Installer is responsible to select the right size wire for run length and total wattage for each circuit. Do not exceed 90 watts per circuit.

TIVOTAPE™ PAD DESIGNATION	LEAD WIRE COLOR	SUB-CONTROLLER TERMINAL OR ADNM-DIN CONNECTOR WIRE COLOR
+	Green (+)	Black (+)
-	Red	Red
+	Blue (+)	Black (+)
-	Black	Green

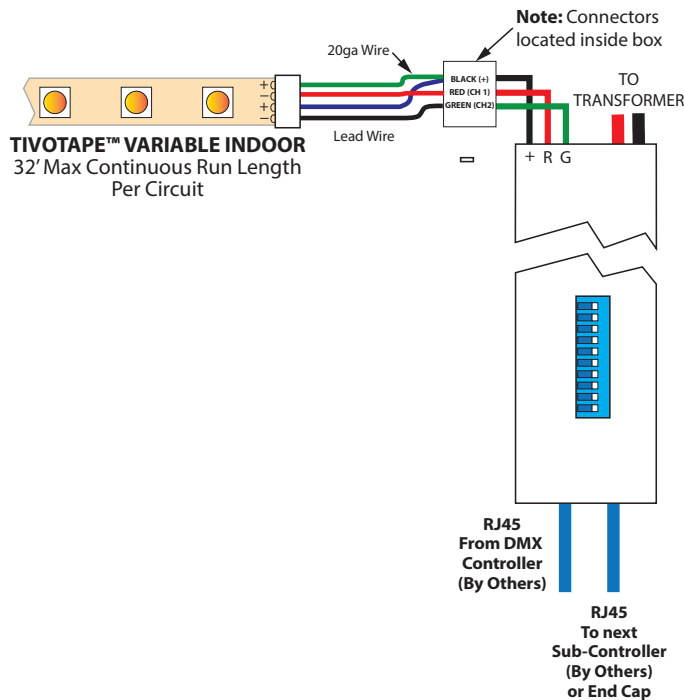

Connect RGB Controller to Sub-Controller

Step 1: Interconnect RGB controller (DMX512 signal) to Sub-Controller using CAT5 Cable with RJ45 connectors. Refer to the diagram for custom wiring applications. Be sure to maintain correct polarity if custom wiring is required.

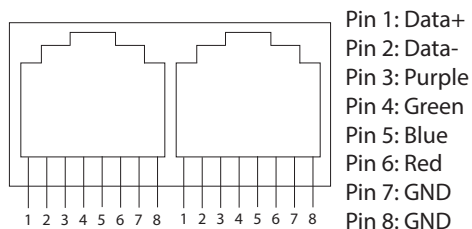

DMX-512 Address Code Setting

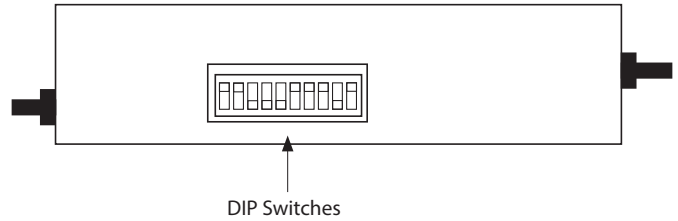

This sub-controller has a total of 512 address codes. 1 represents the least significant byte (LSB) and 9 is most significant byte (MSB). The initial address code is the DMX signal received by Channel 1 of the decoder. Channel 2 will receive data on the initial address code + 1 and Channel 3 will receive data on the initial address code + 2. The initial address code is the sum of DIP switches 1-9 in the "On" position. The 10th switch is not used.

Move a switch up to turn it on and leave it in the down position to achieve a "0" value.

Value of each DIP Switch

DIP	1	2	3	4	5	6	7	8	9
VALUE	1	2	4	8	16	32	64	128	256

Example: Set to 38

Set the 2nd, 3rd and 6th switch to "1" and set the rest to "0". The sum of the switches is 2+4+32 for an address of 38.



Basic Programming Codes:

RED: 1 off, 2 through 9 on
BLUE: 1 and 2 off, 3 through 9 on
GREEN: 2 off, 1 and 3 through 9 on
WHITE: 3 off, 1, 2 and 4 through 9 on
DMX SIGNAL: 1 on, 2 through 9 off

Power Supply Wiring Diagram with 3 Channel DMX Sub-Controller

TIVOTAPE™ VARIABLE INDOOR
32' Max Continuous Run Length

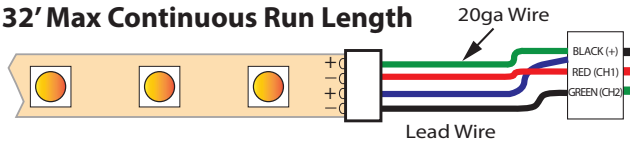

ADNM-90-1-4-24-VW
Outdoor (NEMA 3 Rated)
90W / 1 Circuit X 4A
Box Size: 6.00"W X 8.25"L X 4.50" D

